

# SECTION 7

## CAR HEATER

The car heater is of a hot water type and is heated by the engine coolant and circulates through a network of pipes into the car interior by the action of a blower motor. The blower motor is driven electrically and operates effectively over a wide range of engine speeds. The blower motor is of a low speed type and is controlled by a blower motor switch. Under this condition, if a low speed blower motor is used, the battery voltage is applied to the blower motor and the blower motor runs at full speed.

### CONTENTS

7-1. DESCRIPTION .....	7-2
7-2. ELECTRICAL CIRCUIT .....	7-3
7-3. HEATER SERVICES .....	7-4
7-4. REMOVAL AND INSTALLATION .....	7-5



Fig. 7-2



## 7-1. DESCRIPTION

The car heater is of a hot water type and operates quietly. The air is heated by the engine coolant and the warm air is blown into the car interior by the blower motor.

The blower motor is driven electrically, independent of engine speed, and operates effectively even when the engine speed is low.

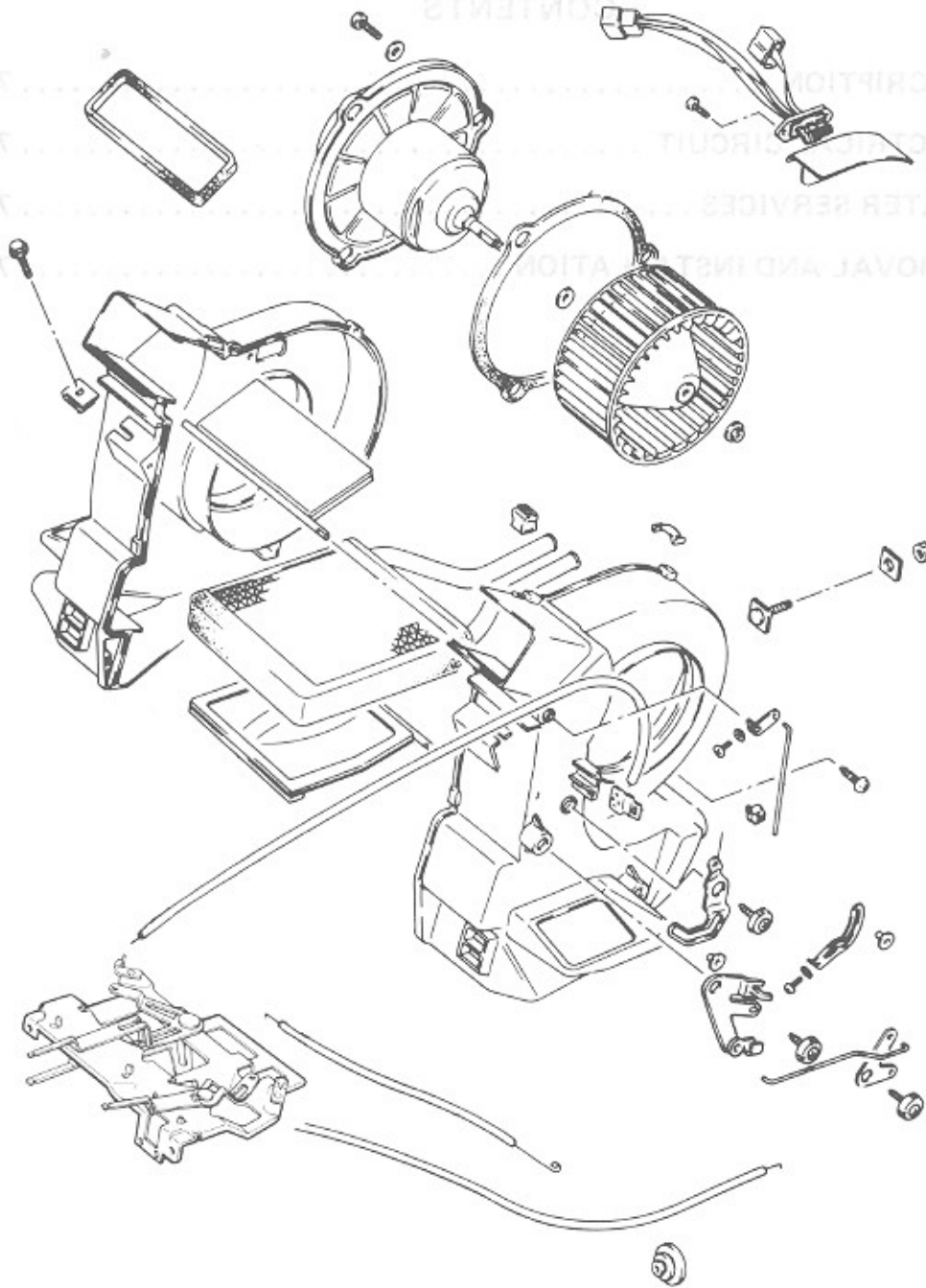

Fig. 7-1



### 7-3. HEATER SERVICES

#### Blower resistor

This resistor is on heater case. Check it for signs of cracking or breakage and replace as necessary. If blower motor will not run or when resistor is replaced, check continuity between Blue/White and Blue/Black terminals using a circuit tester.

Blower resistor specification	Several ohms
-------------------------------	--------------

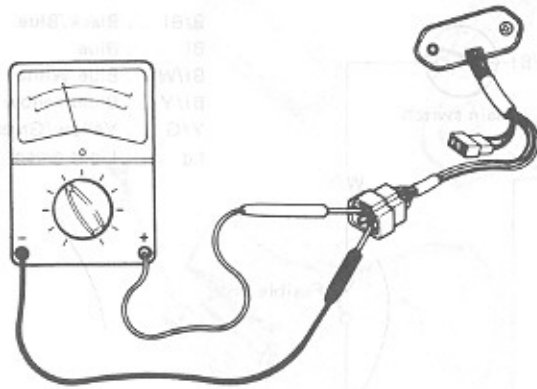

Fig. 7-3

#### Blower switch

Using a circuit tester, check this switch for circuit continuity:

III	○	—	○	
II	○	—	○	
I	○	○		
OFF				
	Black	Blue/red	Blue/Yellow	Blue

#### Heater hoses

Check heater hoses for the connection condition, breakage, cracks and other damage and replace if necessary.

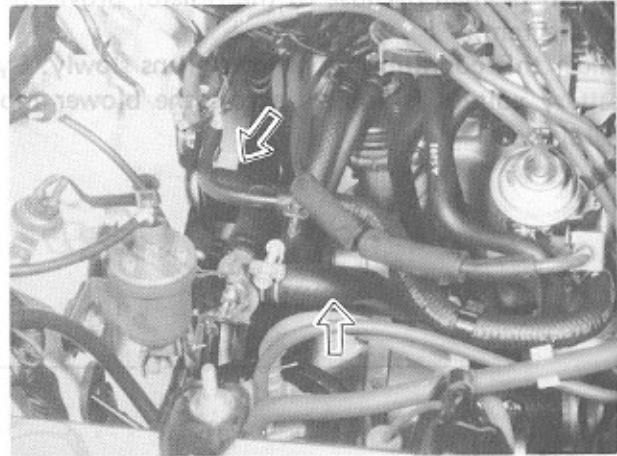

Fig. 7-4

## 7-4. REMOVAL AND INSTALLATION

### Removal

[Heater and blower motor]

1. Disconnect battery negative cable.
2. Drain cooling system.

#### WARNING:

To help avoid the danger of being burned, do not remove the drain plug and the radiator cap while the engine and radiator are still hot.

Scalding fluid and steam can be blown out under pressure if the plug and cap are taken off too soon.

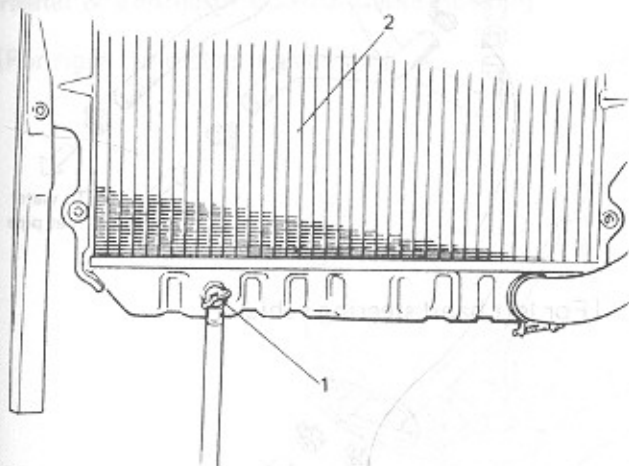

Fig. 7-5 1. Drain plug 2. Radiator

3. Disconnect heater inlet and outlet hoses from heater unit pipes.
4. Remove instrument panel ass'y with speedometer ass'y as follows.
  - 1) Take off horn pad and remove steering wheel using special tool (A).

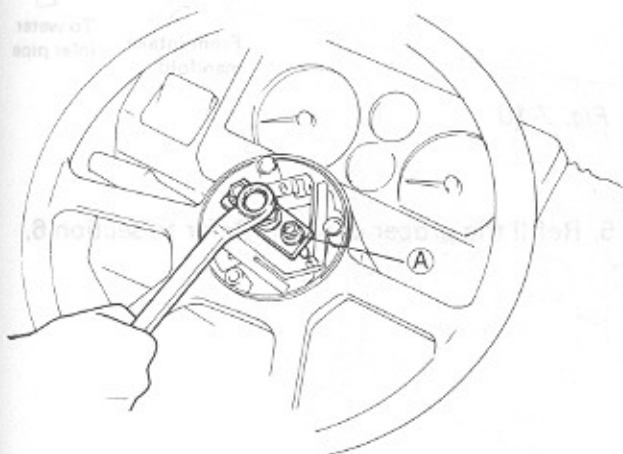

Fig. 7-6 (A) Special tool (Steering wheel remover 09944-36010)

- 2) If equipped with radio and cigarette lighter, disconnect radio and cigarette lighter lead wires, and pull out radio case with radio and cigarette lighter after loosening case stay screw, and remove radio case bracket.
- 3) Pull out ashtray and loosen ashtray plate screws.
- 4) Disconnect front hood opening cable from lock ass'y.
- 5) Loosen panel box stay screw and hood opening cable lock nut on back side of panel box cover.
- 6) Disconnect lead wires to control lever at the coupler and heater control cables.
- 7) Pull out lever knobs and plate, and loosen lever case screws.
- 8) Remove defroster and side ventilator hoses.
- 9) Disconnect lead wires to speedometer and switches installed instrument panel at the couplers.
- 10) Disconnect speedometer cable from speedometer.
- 11) Release wire harness clamps installed to instrument panel.
- 12) Loosen screws securing instrument panel.
- 13) Remove instrument panel.

#### NOTE:

- Before removing, recheck to ascertain all hoses, wire harness, cables and screws are disconnected from instrument panel.
  - When removing heater lever case which is fitted in steering column holder, be very careful not to damage it.
5. Remove steering column holder after loosening front door open stopper screws.

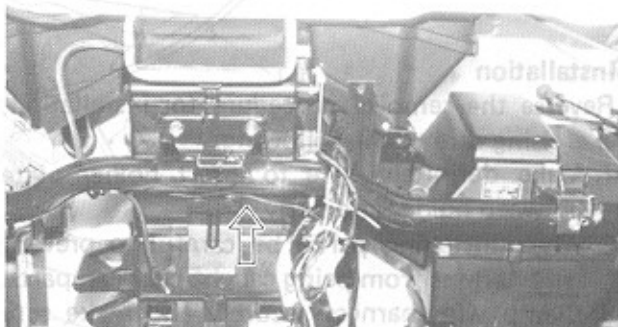

Fig. 7-7

- Disconnect heater blower motor and resistor lead wires at the coupler.
- Loosen heater case securing nut on the engine room side.



Fig. 7-8

- Remove heater ass'y.

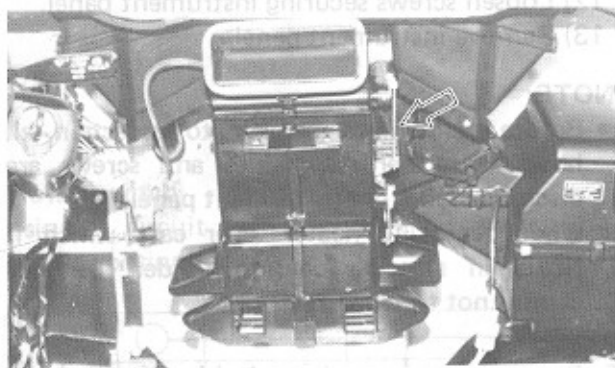

Fig. 7-9

- Remove heater blower motor.

### Installation

Reverse the removal procedure for installation, exercising care to the following.

- Make definitely sure to insert holder plate between holder and body.
- When installing parts, be careful to prevent wire harness from being caught between parts.
- Clamp wire harness securely and make sure that it does not contact sharp edge of any part.

- When connecting heater hoses, route them correctly making sure they are free from twist.

[For right hand steering vehicle]

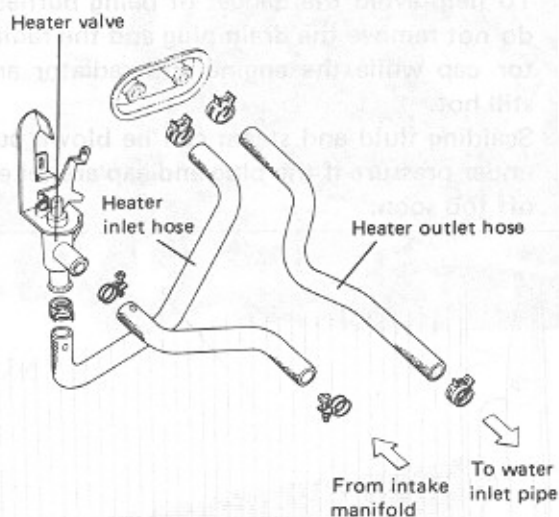

[For left hand steering vehicle]

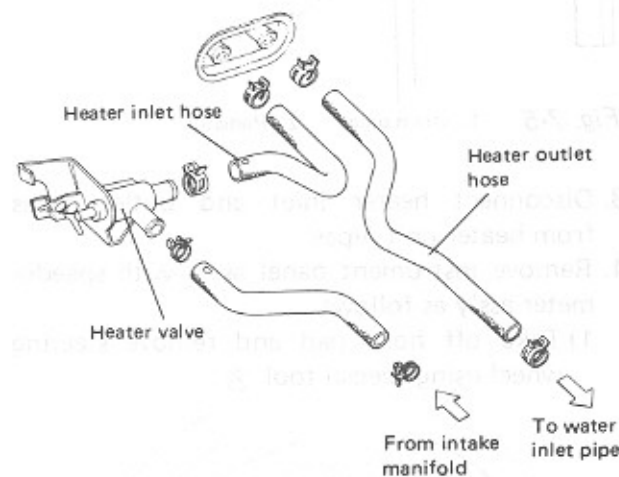

Fig. 7-10

- Refill the proper coolant. Refer to section 6.

**NOTE:**

Upon completion of all jobs, perform following checks.

- Check to ensure that every joint of each heater hose and pipe is free from leakage of cooling water.
- Check to ensure that each control lever operates smoothly and that car heater operates correctly to each control lever position. If found faulty, adjust by changing control cable clamp position.
- Check to ensure that each wire harnesses are securely clamped.

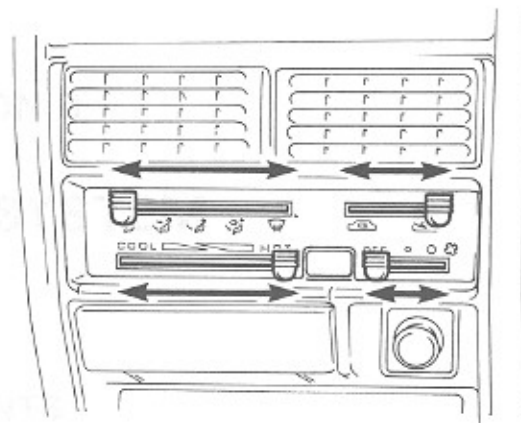
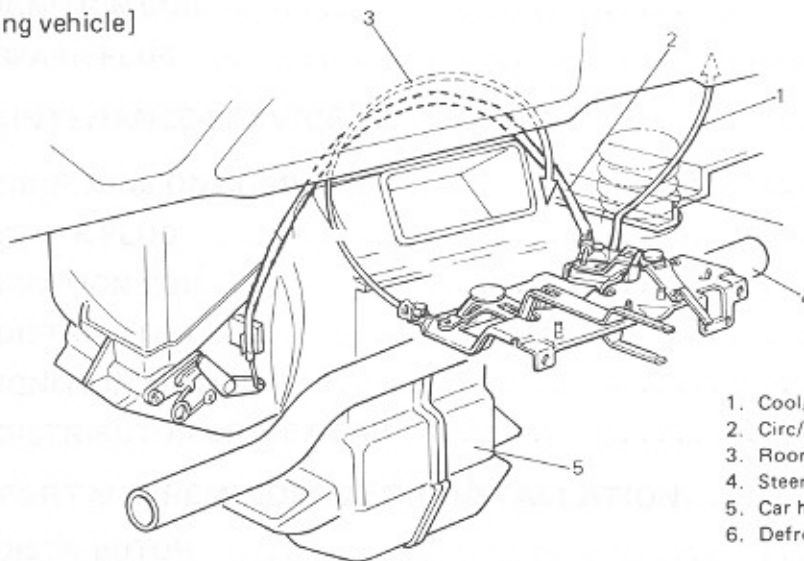

Fig. 7-11

**Heater & Ventilator Control Cable Routing**

[For right hand steering vehicle]



1. Cool/hot cable
2. Circ/fresh cable
3. Room/def. cable
4. Steering column holder
5. Car heater
6. Defroster hose

[For left hand steering vehicle]

